



1,150 HP AC Drilling Motor – HAW20B115



For Top Drive Applications

Benchmark Performance for Oil & Gas Applications

The Houma Armature 1,150 HP (HAW20B115) AC Motor is designed to deliver or exceed customer specifications for performance, productivity and durability. Engineered to withstand decades of continuous service, this rugged 1,150 HP motor is ideally suited for top drive applications in the extreme environments where oil and gas rigs operate either on or off-shore.

Standard Features

- 6 pole stator with form wound windings
- Extra tough pitch copper rotor bars
- Certified Class H insulation
 - Robotically taped Mica-Kapton
 - Glass sleeving on bolted wire connections
 - Fully vacuum impregnated
- 4140 and 4340 alloy shafts available
- Six 100Ω platinum RTDs; 2/phase embedded in stator
- Shaft seals and oil slingers on the drive and non-drive sides

- Designed for Variable Frequency Drive operation
- Heater
- Double shaft extension (tapered, splined or keyed)
- ABS and ISO 9001:2015-certified
- ATEX and CSA-approved

Optional Features

- Encoder
- Bearing RTD
- Blower assembly
- Air pressure switch
- IP 56 junction box
- IP 44 motor enclosure
- Insulated bearing on non-drive end



ABS-certified



ISO 9001:2015-certified



ATEX-approved



CSA-approved



1,150 HP AC Drilling Motor



Speed - Torque Performance That Leads the Industry

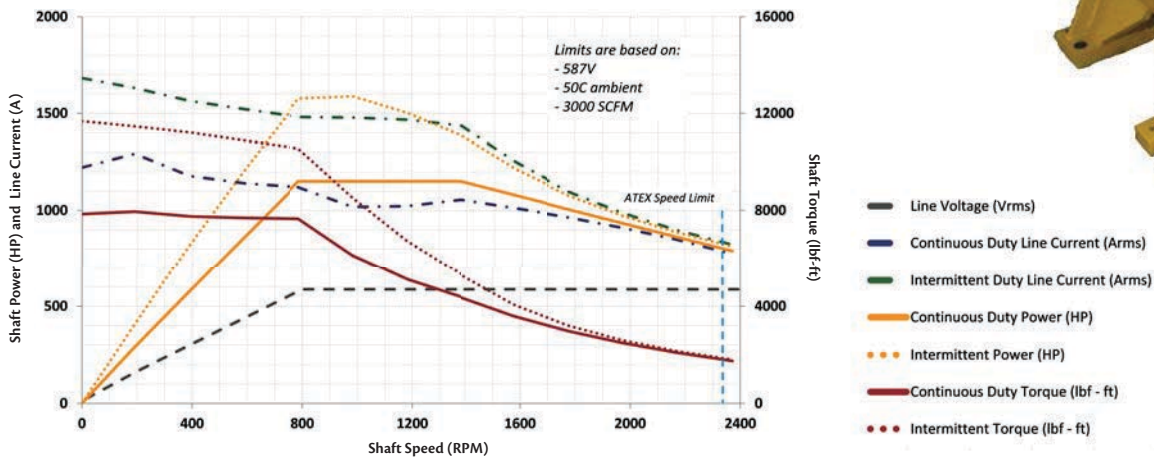

Critical Data

Model number	HAW20B115B
Voltage (AC)	575 ±10%
Current (Amps)	1120
Rated Speed	795 RPM
Torque (lb ft)	7595 at rated speed
HP	1150 at rated speed
Max. permissible speed	2300 RPM
Base motor weight	6,000 lbs.
Rotor weight	2,300 lbs
Recommended blower CFM	3,000
Nominal resistance / phase @ 25 °C	0.0037 Ω
Rotor balance	50 gram inches
Standard bearing grease	Mobil Unirex EP 2 *
Megger resistance	20 MΩ

* Others available upon request.

Dimensions

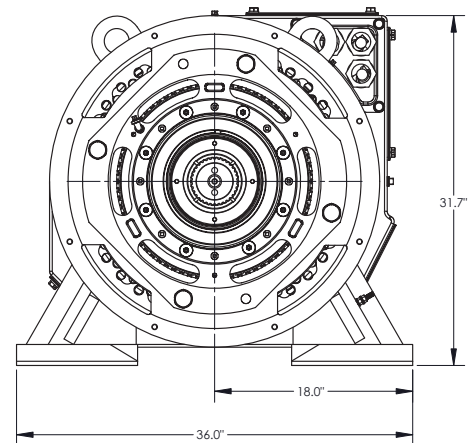

Houma Armature Works is a global provider of highly engineered motors, controls and integrated solutions that power Oil & Gas exploration. We provide benchmark performance, productivity, durability and customer support primarily for Top Drives, Mud Pumps, Draw Works, Rotary Tables, Engine Control and Control Houses. Learn more at www.houmaarmature.com.

2534 Cummins Road, Houma, LA 70363 | 800.673.0531
8100 McHard Road, Houston, TX 77053 | 713.748.0702